

2/2-way valves DN 8 to DN 50

For neutral steam and liquids

Solenoid actuated, with forced lifting

Piston valves

Internal threads G 1/4 to G 2 or 1/4 NPT to 2 NPT

Operating pressure 0 to 16 bar

85720

85730

Click-on[®]

Description (standard valve)

Solenoid valve for steam, hot water, and other neutral liquids

Switching function:	normally closed
Flow direction:	determined
Fluid temperature:	0 °C up to max. +200 °C
Ambient temperature:	0 °C up to max. +60 °C
Mounting position:	Solenoid mounted underneath (up to max. +150 °C preferably solenoid vertical on top)

Material

Body:	Brass (CW617N)
Seat seal:	PTFE
Internal parts:	Stainless steel, PTFE/Carbon/FPM

For contaminated fluids insertion of a strainer is recommended.

Features

- High flow rate
- For robust industry applications
- Damped operation
- Valve operates without differential pressure
- Solenoid interchangeable without tools (**Click-on[®]**) up to G 1 thread

Symbol

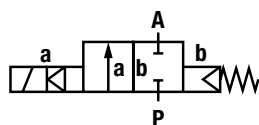

Ordering information

To order, quote model number from table overleaf, e. g. 8572400.9402 for a DN 25 valve.



Characteristic Data

Valves

Part Number Solenoid with ≡	Part Number Solenoid with ~	Nominal Diameter (mm)	Connection Size	Operating Pressure *		k _v -value ** (Base m ³ /h)	Weight Total (kg)
				min.	max. (bar)		
8572000.9402 8573000.9402	8572000.9406 8573000.9406	8	G 1/4 1/4 NPT	0	16	1.9	2.4
8572100.9402 8573100.9402	8572100.9406 8573100.9406	10	G 3/8 3/8 NPT	0	16	3.0	2.4
8572200.9402 8573200.9402	8572200.9406 8573200.9406	12	G 1/2 1/2 NPT	0	16	3.8	2.5
8572300.9402 8573300.9402	8572300.9406 8573300.9406	20	G 3/4 3/4 NPT	0	16	6.1	2.7
8572400.9402 8573400.9402	8572400.9406 8573400.9406	25	G 1 1 NPT	0	16	9.5	3.1
8572500.8402 8573500.8402	8572500.8406 8573500.8406	32	G 1 1/4 1 1/4 NPT	0	16	23.0	5.6
8572600.8402 8573600.8402	8572600.8406 8573600.8406	40	G 1 1/2 1 1/2 NPT	0	16	25.0	5.4
8572700.8402 8573700.8402	8572700.8406 8573700.8406	50	G 2 2 NPT	0	16	41.0	6.8

* for gases and liquid fluids up to 40 mm²/s (cSt)

State voltage [V] and frequency [Hz]

** C_v-value (US) ≈ k_v-value x 1.2

Solenoid 9402 / 9406 and 8402 / 8406

Standard voltage

DC ≡	AC ~ 40 Hz – 60 Hz	
	24 V	–
–	110 V	120 V
–	230 V	220 V

Design acc. to DIN VDE 0580

Voltage range ±10 %

100 % duty cycle

Protection class acc. to EN 60529 IP65

Socket Form A acc. to DIN EN 175301-803 (included)

AC with rectifier plug

Power Consumption

According to DIN VDE 0580 at coil temperature of +20 °C. In operation the power consumption of the solenoid decreases by approx. 30 %.

Solenoid	DC ≡	AC ~	
		Inrush	Holding
9402 *	29 W	–	–
9406 *	–	33 VA	33 VA
8402	29 W	–	–
8406	–	33 VA	33 VA

*  coil only
(with the exception of solenoid 94xx up to 41 V AC)

Attention!

The conditions imposed on the Ex approvals lead to reduction of the permissible standard temperature ranges in the cases of explosion protected solenoids.

Further Options (Valves)

XXXXX01.XXXX Normally open,
from G 1/2 with solenoid 8402 / 8406
Mounting position and Fluid temperature
max. +150 °C solenoid vertical on top,
max. +200 °C solenoid vertical underneath;
G 1 1/4 only vertical on top

XXXXX02.XXXX Manual override

XXXXX14.XXXX Seat seal EPDM,
max. Fluid temperature +130 °C

XXXXX22.XXXX max. operating pressure 25 bar

XXXXX23.XXXX Position indicator with two solenoid sensors,
only with solenoid 8400

On request Further versions

Accessories :
- Manual override conversion kit
- Mounting bracket conversion kit

Further Options (Solenoids)

On request Further versions

Section View

up to G 1 resp. 1 NPT

- 101 Valve body
- 102 Valve cover
- *103 Valve piston
- 104 Socket head cap screw
- *105 Pressure spring
- *106 O-ring
- *107 O-ring
- *108 Grooved ring
- 400 Solenoid
- 701 Core tube
- *702 Straight pin
- 703 Round plate
- *704 Pressure spring
- *705 Core
- 706 Spring clip
- *707 O-ring
- 1400 Socket (included)

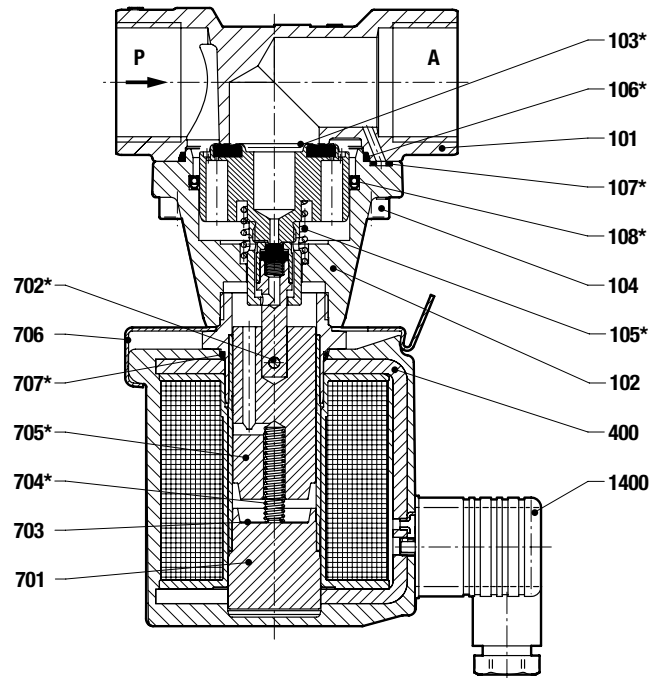

from G 1 1/4 resp. 1 1/4 NPT

- 101 Valve body
- 102 Valve cover
- *103 Valve piston
- 104 Socket head cap screw
- *105 Pressure spring (2x)
- *106 O-ring
- *107 O-ring
- *108 Grooved ring
- 400 Solenoid
- 701 Core tube
- *702 Straight pin
- 703 Round plate
- *704 Pressure spring
- *705 Core
- 1400 Socket (included)
- 1501 Hexagon screw
- 1502 Round plate
- *1504 O-ring (2x)

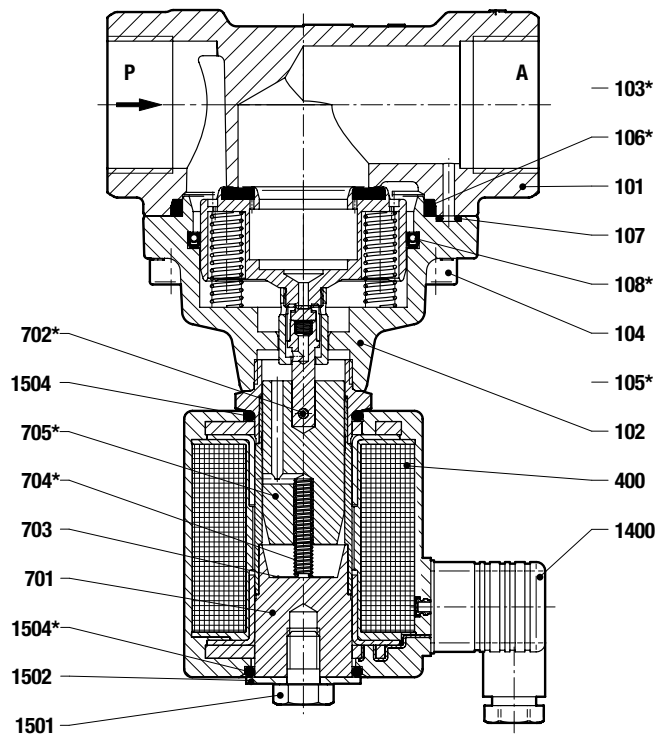

* These individual parts form a complete wearing unit.
When ordering spare parts please state Cat. No. and Series No.

General Dimensions

Solenoid rotatable 360°
 Socket turnable 4 x 90°
 (Socket included)

up to G 1 resp. 1 NPT

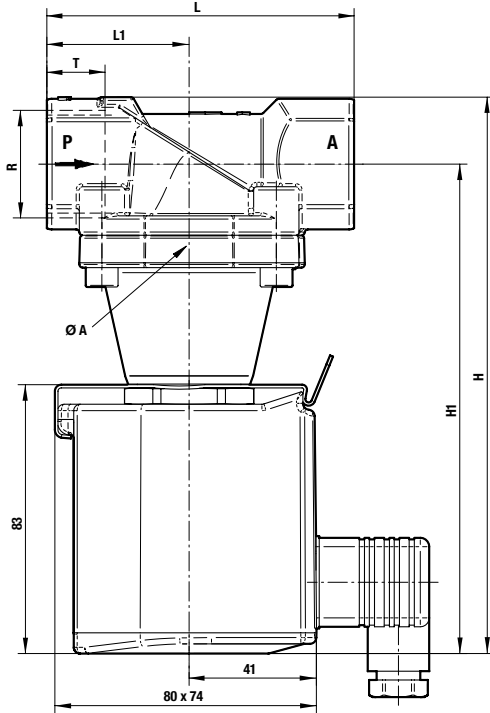

from G 1 1/4 rep. 1 1/4 NPT

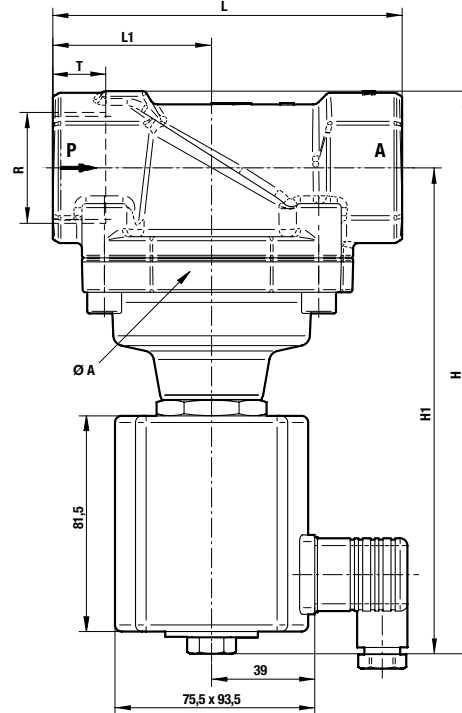

Part Number	Nominal Diameter (mm)	Connection Size	A (mm)	H (mm)	H 1 (mm)	L (mm)	L 1 (mm)	T (mm)
8572000.940x 8573000.940x	8	G 1/4 1/4 NPT	44	152.0	140.5	60	27.5	12.0 10.0
8572100.940x 8573100.940x	10	G 3/8 3/8 NPT	44	152.0	140.5	60	27.5	12.0 10.5
8572200.940x 8573200.940x	12	G 1/2 1/2 NPT	44	154.5	140.5	67	31.0	14.0 13.5
8572300.940x 8573300.940x	20	G 3/4 3/4 NPT	50	162.0	146.5	80	35.5	16.0 14.0
8572400.940x 8573400.940x	25	G 1 1 NPT	62	183.0	162.0	95	44.0	18.0 17.0
8572500.840x 8573500.840x	32	G 1 1/4 1 1/4 NPT	92	212.5	183.5	132	60.0	20.0 17.0
8572600.840x 8573600.840x	40	G 1 1/2 1 1/2 NPT	92	212.5	183.5	132	60.0	22.0 17.0
8572700.840x 8573700.840x	50	G 2 2 NPT	109	226.5	192.0	160	74.0	24.0 17.5

Note to Pressure Equipment Directive (PED):

The valves of this series, including the connection size DN 25 (G 1), are according to Art. 3 § 3 of the Pressure Equipment Directive (PED) 97/23/EG. This means interpretation and production are in accordance to engineers practice wellknown in the member countries.

The CE-sign at the valve refers not to the PED. Thus the declaration of conformity is not longer applicable for this directive.

For valves > DN 25 (G 1) Art. 3 § (1) No.1.4 applies.

The basic requirements of the Enclosure I of the PED must be fulfilled. The CE-sign at the valve includes the PED. A certificate of conformity of this directive will be available on request.

Note to Electromagnetic Compatibility Guideline (EEC):

The valves shall be provided with an electrical circuit which ensures the limits of the harmonised standards EN 61000-6-3 and EN 61000-6-1 are observed, and hence the requirements of the Electromagnetic Compatibility Guideline (2004/108/EG) satisfied.