

# 2/2-way valves ND 15 to 100



for slightly aggressive gaseous and liquid fluids  
 Solenoid actuated, with forced lifting  
 Piston seat valves  
 Flange connection PN 25 / PN 40  
 Operating pressure 0 to 25 bar

**Stainless Steel**

Publication 7502710.06.12.94  
 Catalogue index  
**A 5**  
 85 240 / 84 240 series

## Description (standard valve)

**Stainless steel solenoid valve for slightly aggressive gaseous and liquid fluids**

**Flow direction:** determined  
**Fluid temperature:** -20 °C to +90 °C up to ND 50  
 -10 °C to +90 °C from ND 65  
**Ambient temperature:** max. +50 °C  
**Sum of fluid- and ambient temperature:** max. +130 °C  
**Mounting position:** optional, solenoid preferably vertical on top, ND 65 and larger, only vertical on bottom  
**Material Body:** Stainless steel (1.4581) B.S. 318 C17  
**Seat seal:** NBR, cold flexibel  
**Internal parts:** 1.4571, 1.4301, 1.4310; Sandvik 1802 up to ND 50; 1.4104 and 1.4105 from ND 65



For contaminated fluids insertion of a strainer is recommended (see accessories).

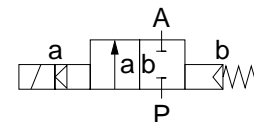

## Features

- Valve operates without pressure differential ( $\Delta p$ )
- High flow rate
- Damped operating
- Suitable for vacuum

**Switching function:**  
 Normally closed

## Characteristic data

ND [mm]	Operating pressure with gaseous and liquid fluids up to 40 mm <sup>2</sup> /s (cSt) [bar]		k <sub>v</sub> -value <sup>1)</sup> (Base m <sup>3</sup> /h)	Weight [kg]	Section no	Dimension table no	Cat no			
	min.	max.					Valve XX XXX	Solenoid DC XX XXXX	Valve XX XXX	Solenoid AC XX XXXX
15	0	25	5.5	5.5	01/02	01	85 242	00. 8301	85 242	00. 8304
20	0	25	10.0	5.8	01	02	85 243	00. 8401	85 243	00. 8404
25	0	25	12.5	6.2	01	03	85 244	00. 8401	85 244	00. 8404
32	0	25	27.0	11.0	01	04	85 245	00. 8401	85 245	00. 8404
40	0	25	31.0	11.8	01	05	85 246	00. 8401	85 246	00. 8404
50	0	25	43.0	14.0	01	06	85 247	00. 8401	85 247	00. 8404
65	0	25	67.0	36.5	02	07	84 248	00. 9501	84 248	00. 9504
80	0	25	94.0	46.5	02	08	84 249	00. 9501	84 249	00. 9504
100	0	25	144.0	70.0	02	09	84 250	00. 9501	84 250	00. 9504

State voltage [V] and frequency [Hz]

<sup>1)</sup> C<sub>v</sub>-value (US) ≈ k<sub>v</sub>-value x 1.2

## IMI Norgren Buschjost GmbH + Co. KG

PO Box 10 02 52-53  
 D-32502 Bad Oeynhausen

Tel +49 (0) 57 31 79 10  
 Fax +49 (0) 57 31 79 11 79

<http://www.buschjost.com>  
 e-mail: [mail@buschjost.de](mailto:mail@buschjost.de)

## Solenoids

Standard voltages	DC	AC 40 Hz to 60 Hz
	24 V – 205 V	24 V 110 V 230 V

Design acc. to VDE 0580

Voltage range  $\pm 10\%$

100 % duty cycle

Protection class acc. to EN 60529 IP 65  
(previous DIN 40050)

**Attention! Restricted temperature range for explosion proof solenoids.**

For technical details see catalog register "Solenoids"

## Further models

available at extra cost

- XX XXX **01.XXXX** Normally open, mounting position: solenoid vertical on top <sup>4)</sup>
- XX XXX **02.XXXX** Manual override
- XX XXX **03.XXXX** Seat seal FPM, fluid temperature -10 °C to +110 °C
- XX XXX **06.XXXX** Seat seal PTFE, from ND 65, max. fluid temperature +110 °C <sup>2)</sup>
- XX XXX **14.XXXX** Seat seal EPDM <sup>3)</sup>
- XX XXX **22.XXXX** Operating pressure max. 40 bar, up to ND 50 <sup>4)</sup>
- XX XXX **23.XXXX** Position indicator with two solenoid switches <sup>4)</sup>
- XX XXX **34.XXXX** Enlarged closing force, advisable at low flow rate and low switching cycles
- **On request** Version for aggressive fluids, liquid fluids up to 80 mm<sup>2</sup>/s, further versions

<sup>2)</sup> ND 15 up to 50 see series 85 140, publication 7502710 up to max. +200 °C fluid temperature, solenoid with higher power consumption

<sup>3)</sup> up to max. +110 °C fluid temperature with standard solenoid, up to max. +130 °C fluid temperature solenoid with higher power consumption

<sup>4)</sup> ND 15 with solenoid 8401/8404

## Power consumption <sup>1)</sup>

Solenoid	DC	AC Inrush and Holding
8301	22 W	–
8304	–	25 VA
8401	40 W	–
8404	–	45 VA
9501	80 W	–
9504	–	89 VA

Socket acc. to DIN 43650

AC solenoid with rectifier.

<sup>1)</sup> According to VDE 0580 at coil temperature +20 °C. In operating the solenoid coil decrease the power consumption appr. 30%.

- XX XXX XX.**8402** Solenoid for higher temperature, max. fluid temperature +200 °C, mounting position: vertical, with solenoid underneath, for DC only
- XX XXX XX.**8406** Same as 8402, for AC only
- XX XXX XX.**8436** Solenoid in protection class EEx me II T4
- XX XXX XX.**8441** Solenoid in protection class EEx me II T3
- XX XXX XX.**9502** Solenoid for higher temperature, max. fluid temperature +150 °C
- XX XXX XX.**9540** Solenoid in protection class EEx me II T3 and T4, from ND 65
- XX XXX XX.**8900** Solenoid in protection class EEx de IIC T4 and T5, up to ND 50
- XX XXX XX.**8920** Solenoid in protection class EEx d IIC T4 and T5, up to ND 50
- **On request** Overexcitation, solenoid in protection class EEx d I, EEx de I, special connections



# Dimensions

01

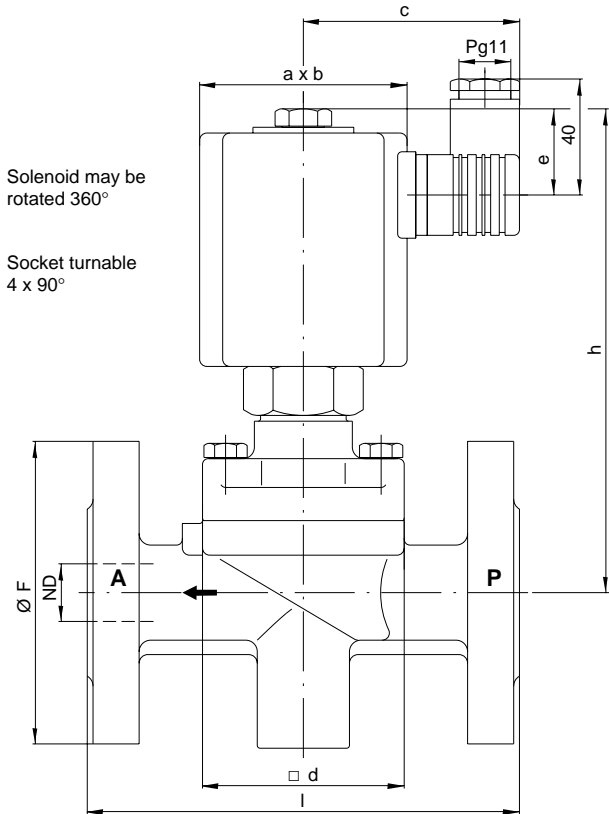

Flange connection PN 16 acc. to DIN 2545 Contact face DIN 2526 type C

Dimension table no	a x b	c	□ d	e
01	52 x 65	65	70	26
02	72 x 92	75	70	31
03	72 x 92	75	70	31
04	72 x 92	75	96	31
05	72 x 92	75	96	31
06	72 x 92	75	112	31
Dimension table no	h	l	ND	Ø F
01	145	130	15	95
02	172	150	20	105
03	172	160	25	115
04	187	180	32	140
05	191	200	40	150
06	200	230	50	165

02

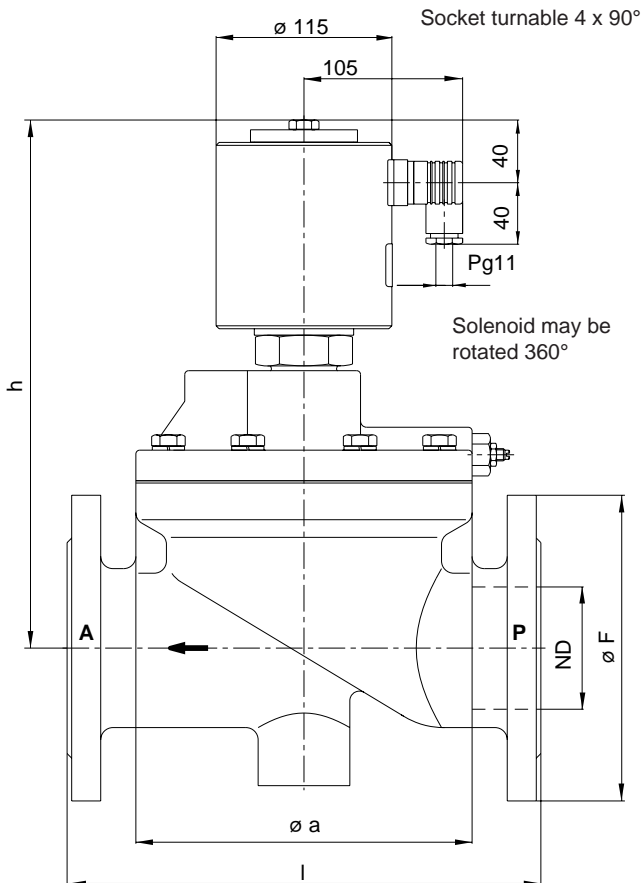

Flange connection PN 16 acc. to DIN 2545/2544 Contact face DIN 2526 type C

Dimension table no	Ø a	h	l
07	195	330	290
08	220	350	310
09	260	378	350
Dimension table no	ND	Ø F	
07	65	185	
08	80	200	
09	100	220	