

2/2-way valves ND 15 to 100



for neutral steam and liquid fluids
 Solenoid actuated, with forced lifting
 Piston seat valves
 Flange connection PN 25
 Operating pressure 0 to 16 bar resp. 25 bar

Publication 7500977.06.12.94
 Catalogue index
A 5
 85 220/84 220 series

Description (standard valve)

Solenoid valve for hot water and steam

Flow direction: determined
 Fluid temperature: max. +200 °C
 Ambient temperature: max. +60 °C
 Sum of fluid- and ambient temperature: max. +260 °C
 Mounting position: solenoid preferably to underneath ¹⁾
 Material Body: Gun metal at ND 15, cast steel at ND 20 to 100, with gun metal seat
 Seat seal: PTFE
 Internal parts: 1.4104, 1.4301, gun metal

For contaminated fluids insertion of a strainer is recommended (see accessories).



Features

- Flat piston valve
- Valve operates without pressure differential (Δp)
- High flow rate
- Damped operation

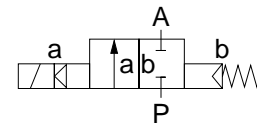

Switching function:
 Normally closed

Characteristic data

ND	Operating pressure with gaseous and liquid fluids up to 80 mm ² /s (cSt) [bar]		k _V -value ⁴⁾ (Base m ³ /h)	Weight [kg]	Section no	Dimension table no	Cat no			
	min.	max.					Valve	Solenoid DC	Valve	Solenoid AC
[mm]							XX XXX XX. XXXX	XX XXX XX. XXXX	XX XXX XX. XXXX	XX XXX XX. XXXX
15	0	16	5	4.0	01	01	85 222 00. 8302	85 222 00. 8306	85 222 00. 8306	85 222 00. 8306
20	0	16	8	5.8	01	02	85 223 00. 8402	85 223 00. 8406	85 223 00. 8406	85 223 00. 8406
25	0	16	10	6.2	01	03	85 224 00. 8402	85 224 00. 8406	85 224 00. 8406	85 224 00. 8406
32	0	16	27	11.0	01	04	85 225 00. 8402	85 225 00. 8406	85 225 00. 8406	85 225 00. 8406
40	0	16	30	11.8	01	05	85 226 00. 8402	85 226 00. 8406	85 226 00. 8406	85 226 00. 8406
50	0	16	41	14.0	01	06	85 227 00. 8402	85 227 00. 8406	85 227 00. 8406	85 227 00. 8406
65	0	25	67	51.0	02	07	85 228 00. 8602			³⁾
65	0	16	67	36.5	03	08	84 228 00. 9502 ²⁾	84 228 00. 9506 ²⁾	84 228 00. 9506 ²⁾	84 228 00. 9506 ²⁾
80	0	25	94	61.0	02	09	84 229 00. 8602			³⁾
80	0	16	94	46.5	03	10	84 229 00. 9502 ²⁾	84 229 00. 9506 ²⁾	84 229 00. 9506 ²⁾	84 229 00. 9506 ²⁾
100	0	25	144	84.0	02	11	84 230 00. 8602			³⁾
100	0	16	144	70.0	03	12	84 230 00. 9502 ²⁾	84 230 00. 9506 ²⁾	84 230 00. 9506 ²⁾	84 230 00. 9506 ²⁾

State voltage [V] and frequency [Hz]

¹⁾ Mounting position for ND 15 to 50 and fluid temperature up to max. +150 °C: solenoid vertical on top

²⁾ Fluid temperature max. +150 °C, mounting position: solenoid only on top

³⁾ For AC-voltage: DC solenoids can be used with a separate rectifier in the switchboard.

⁴⁾ C_V-value (US) ≈ k_V-value x 1.2

IMI Norgren Buschjost GmbH + Co. KG

PO Box 10 02 52-53
 D-32502 Bad Oeynhausen

Tel +49 (0) 57 31 79 10
 Fax +49 (0) 57 31 79 11 79

<http://www.buschjost.com>
 e-mail: mail@buschjost.de

Solenoids

Standard voltages	DC	AC 40 Hz to 60 Hz
	24 V – 205 V	24 V 110 V 230 V

Design acc. to VDE 0580
Voltage range $\pm 10\%$
100 % duty cycle
Protection class acc. to EN 60529 IP 65
(previous DIN 40050)

For technical details see catalog register "Solenoids".

Further models

available at extra cost

- XX XXX **01.XXXX** Normally open.
Mounting position at fluid temperature: max. +150 °C solenoid vertical on top, max +200 °C solenoid vertical underneath, ND 32 up to ND 50 only with solenoids 9502/9506
- XX XXX **02.XXXX** Manual override

Power consumption ¹⁾

Solenoid	DC	AC Inrush and Holding
8302	14 W	–
8306	–	16 VA
8402	29 W	–
8406	–	33 VA
9502	55 W	–
9506	–	61 VA
8602	100 W	–

Socket acc. to DIN 43650 at solenoid 8402/8406/9502/9506
AC solenoid with rectifier.
Terminal in solenoid housing 8602

¹⁾ According to VDE 0580 at coil temperature +20 °C.
In operating the solenoid coil decrease the power consumption appr. 30 %.

- XX XXX **14.XXXX** Seat seal EPDM, up to ND 50, max. fluid temperature +130 °C
- XX XXX **23.XXXX** Position indicator with two solenoid switches
- XX XXX **34.XXXX** Enlarged closing force, advisable at low flow rate and low switching cycles
- **On request** Further versions; Inspection certificate DIN 50049–3.1.B

Sections

01

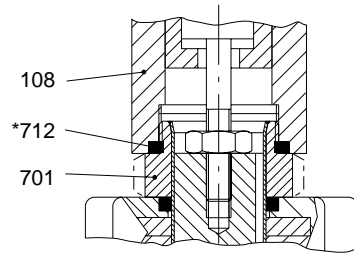
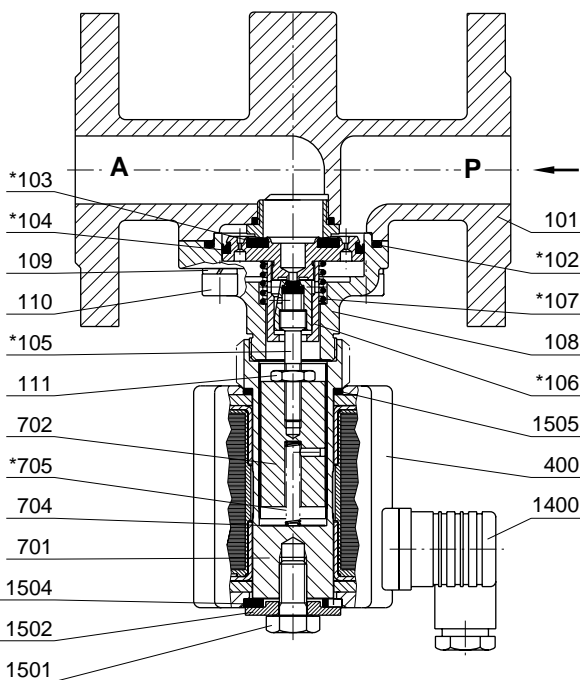

- | | |
|---------------------------|------------------------------|
| 101 Valve body | 701 Core tube |
| *102 O-ring | 702 Core |
| *103 Valve plate | 704 Anti magnetic spacer |
| *104 Grooved ring | *705 Pressure spring |
| *105 Valve spindle | *712 Gasket – for ND 15 only |
| *106 Screw piece | 1400 Socket |
| *107 Pressure spring | 1501 Hexagon screw |
| 108 Body cover | 1502 Round plate |
| 109 Spring washer | 1504 Gasket |
| 110 Cheese head cap screw | 1505 O-ring |
| 111 Hexagon nut | |
| 400 Solenoid | |

02

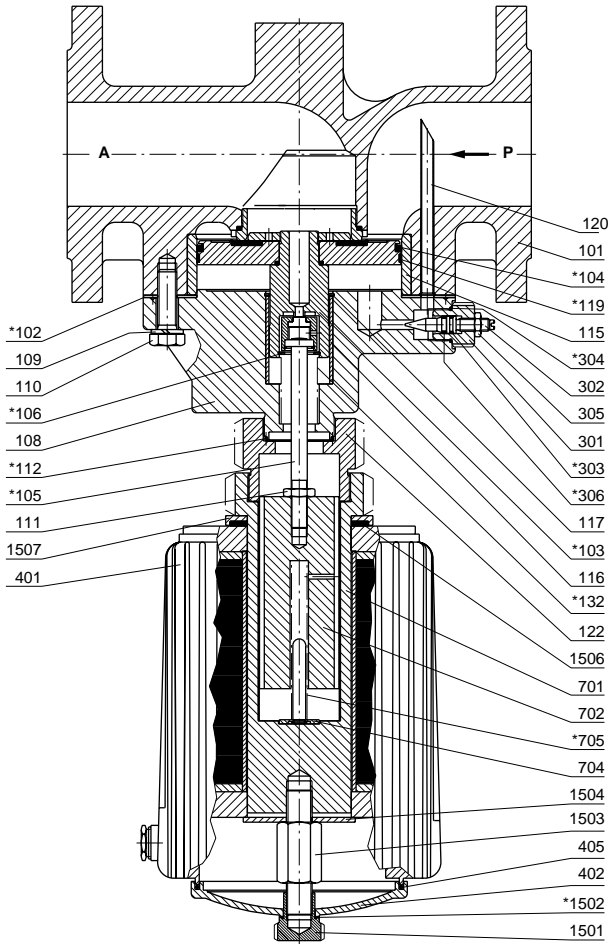

- | | |
|----------------------|---------------------------|
| 101 Valve Body | 305 Hexagon nut |
| *102 Gasket | *306 Grooved ring |
| *103 Valve piston | 401 Solenoid |
| *104 Grooved ring | 402 Solenoid cover |
| *105 Valve spindle | 403 Terminal |
| *106 Locking ring | 404 Cheese head cap screw |
| 108 Body cover | 405 O-ring |
| 109 Spring washer | 406 Earthing plate |
| 110 Hexagon screw | 407 Washer |
| 111 Hexagon nut | 408 Chesse head cap screw |
| 115 Bushing | 701 Core tube |
| 116 Bushing | 702 Core |
| 117 Circlip | 704 Guide pin |
| *119 Guide foil | *705 Pressure spring |
| 120 Tube | 1501 Screw piece |
| *121 Seal ring | 1502 O-ring |
| 122 Screw piece | 1503 Screw piece |
| *132 Pressure spring | 1504 Round plate |
| 301 Screw piece | 1506 Gasket |
| 302 Valve spindle | 1507 Round plate |
| *303 O-ring | |
| *304 O-ring | |

03

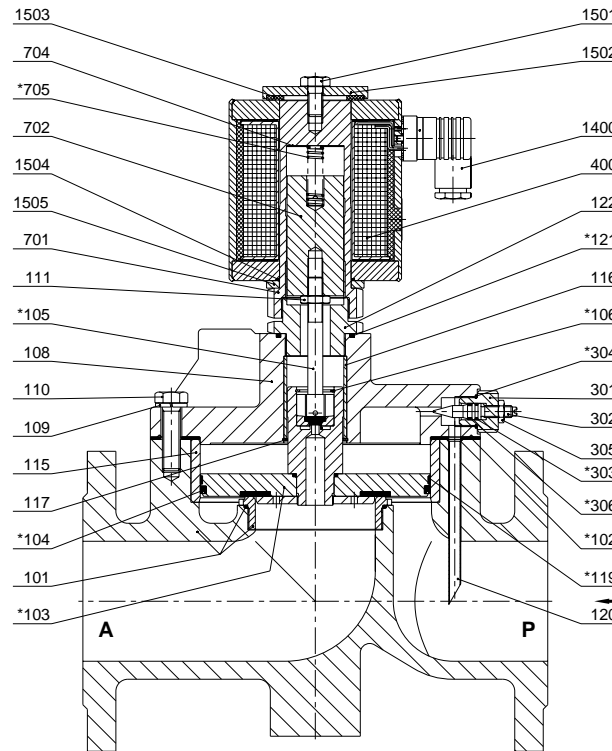

- | | |
|--------------------|--------------------------|
| 101 Valve body | 302 Valve spindle |
| *102 Gasket | *303 O-ring |
| *103 Valve piston | *304 O-ring |
| *104 Grooved ring | 305 Hexagon nut |
| *105 Valve spindle | 306 Grooved ring |
| *106 Locking ring | 400 Solenoid |
| 108 Body cover | 701 Core tube |
| 109 Spring washer | 702 Core |
| 110 Hexagon screw | 704 Anti magnetic spacer |
| 111 Hexagon nut | *705 Pressure spring |
| 115 Bushing | 1400 Socket |
| 116 Bushing | 1501 Hexagon screw |
| 117 Circlip | 1502 Round plate |
| *119 Guide foil | 1503 Gasket |
| 120 Tube | 1504 O-ring |
| *121 Seal ring | 1505 Round plate |
| 122 Screw piece | |
| 301 Screw piece | |

* These individual parts form a complete wearing unit.

When ordering spare parts please state Cat no and series no.

Dimensions

01

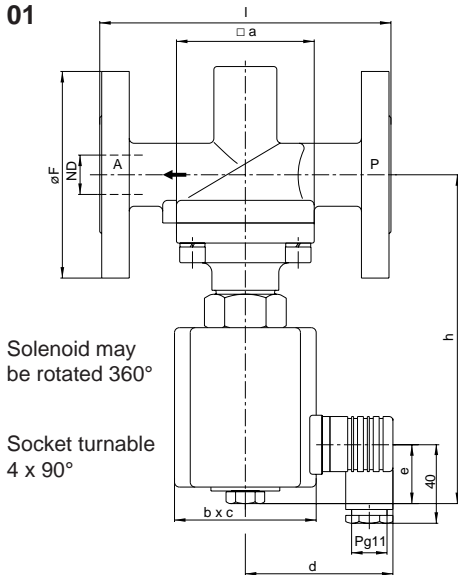

Flange connection PN 25 acc. to DIN 2544/2545
Contact face DIN 2526 type C

Dimension table no	a	b x c	d	e
01	70	52 x 65	65	26
02	70	72 x 92	75	31
03	70	72 x 92	75	31
04	96	72 x 92	75	31
05	96	72 x 92	75	31
06	112	72 x 92	75	31

Dimension table no	h	l	ND	Ø F
01	145	130	15	95
02	172	150	20	105
03	172	160	25	115
04	187	180	32	140
05	191	200	40	150
06	200	230	50	165

Mounting position up to fluid temperature max. +150 °C: preferably solenoid vertical on top

02

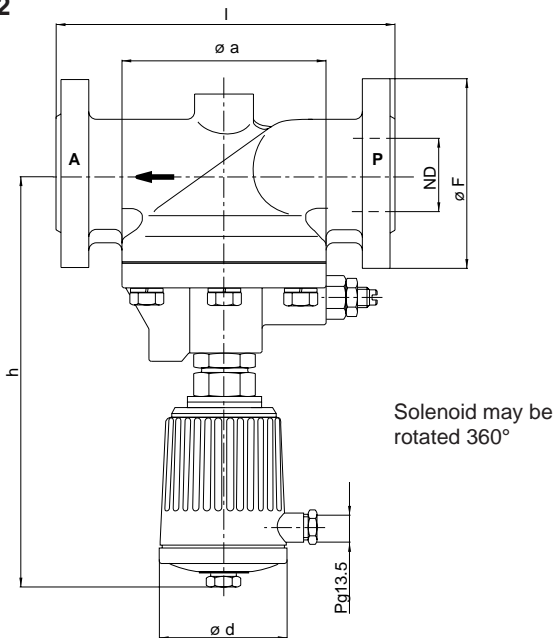

Flange connection PN 25 acc. to DIN 2544/2545
Contact face DIN 2526 type C

Dimension table no	Ø a	Ø d	h
07	195	180	485
08	220	180	505
09	265	180	535

Dimension table no	l	ND	Ø F
07	290	65	185
08	310	80	200
09	350	100	235

Mounting position up to fluid temperature max. +200 °C: solenoid vertical underneath.

03

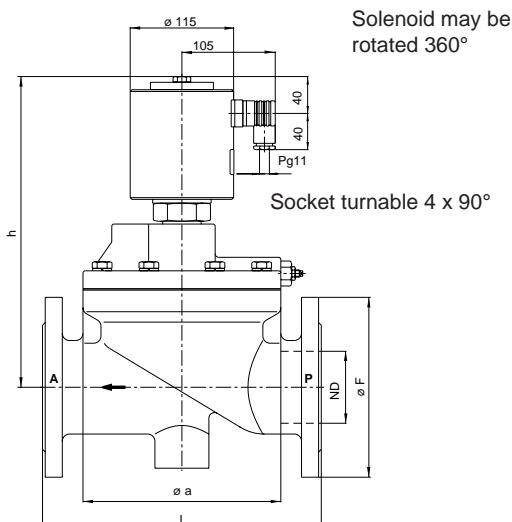

Flange connection PN 25 acc. to DIN 2544/2545
Contact face DIN 2526 type C

Dimension table no	Ø a	h	l
08	195	327	290
10	220	347	310
12	265	376	350

Dimension table no	ND	Ø F
08	65	185
10	80	200
12	100	235

Mounting position up to fluid temperature max. +150 °C: solenoid only vertical to top.