

Motorised valve

For neutral gases and liquids

Internal thread G 1/2 to G 1

Cartridge system

Operating pressure –0.9 to 10 bar

82880

Description (standard valve)

Motorised valve for e.g. hot water, oil, air

Flow direction: determined
 Fluid temperature: max. +90 °C
 Ambient temperature: max. +40 °C
 Mounting position: preferably with drive vertical on top ±60°

Material

Body: Brass (CW617N)
 Seal: NBR
 Control discs: Oxide-ceramic

Features

- Low power consumption
- Choice of compact drives
- Valve remains on last setting if power lost
- Will handle contaminated fluids
- Throttle setting produced by wear-resistant control discs

Symbol:

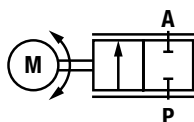

Throttle setting with overlap ¹⁾

Ordering information

To order, quote model number from table overleaf, e.g. 8288300.9615 for a motorised valve DN 20.

¹⁾ Not gastight

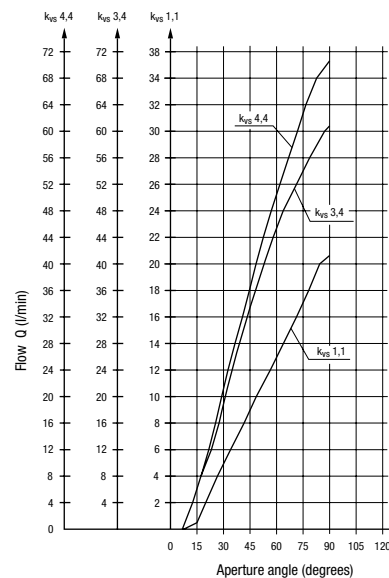

Characteristic curve

Fluid: Water

Δp: 1 bar

Characteristic data

Valves

Part Number (motor ¹⁾)	Nominal Diameter (mm)	Connection size	Operating pressure *		k _s -Wert ** (Base m ³ /h)	Weight (kg)
			min. (bar)	max. (bar)		
8288200.96XX	15	G 1/2	-0.9	10	1.1	0.9
8288300.96XX	20	G 3/4	-0.9	6 ²⁾	4.4	1.6
8288400.96XX	20	G 1	-0.9	6 ²⁾	4.4	1.6

¹⁾ See motor drives for motor Cat no. and power supply

²⁾ Operating pressure increases to 10 bar for 9624 and 9651

Characteristic data

Motor

Motor type	Standard voltage Tolerance ± 10 % [V]	Frequency [Hz]	Power consumption [W]	Protection class	Torque [Ncm]	Operating time through ¹⁾ 90 ° ∇	Wiring diagram	Motor Cat-No.
DC motor	24	-	1.5	IP 54	120	10 - 14 s	01	9615.02400
DC motor	24	-	1.5	IP 54	120	10 - 16 s	02	9650.02400
DC motor	24	-	2.1	IP 54	120	10 - 16 s	03	9657.02400
Synchronous motor	24	50	3.0	IP 54	120	10 s	04	9636.02450
Stepping motor	24	²⁾	5.0	IP 54	120	10 s	05	9638.02400
DC motor	24	-	2.0	IP 54	200	13 s	01	9624.02400 ³⁾
DC motor	24	-	2.5	IP 54	200	13 - 16 s	02	9651.02400 ³⁾

¹⁾ Operating time depends on operating pressure

³⁾ Only in conjunction with G 3/4 and G 1

²⁾ Nominal stepping frequency 200 Hz

Note! All motor drives fulfil the requirements of the generic standards for electromagnetic compability (EN 50081-1 and EN 61000-6-2) to Directive 89/336/EEC.

Limit switch service life >100,000 cycles

Further technical data for DC motor Cat.no. 9615, 9624

Motor with feedback potentiometer for servo-amplifier

Feedback potentiometer

Resistor: 1 k Ω
 Resistor tolerance: ± 20 %
 Max wiper current: 1 mA
 Power rating: 0,1 W

Only part of the potentiometer's range is used.

Further technical data for DC motors Cat Nos 9650 and 9651

Drives with integrated position controller

The set point input can be set to the required signal range with the 2 jumpers.

Power supply residual ripple: max. 1,2 V_{ss}

Set point input:
 0 – 10 V J1, J2 not inserted
 0 – 20 mA J1 inserted, J2 not inserted
 4 – 20 mA J1, J2 inserted

Input signal ripple: max. 40 m V_{ss} with voltage signal
 max. 0,08 mA_{ss} with current signal

Input resistance: 200 k Ω with voltage signal
 500 k Ω with current signal

Auxiliary voltage for external potentiometer: 12 V ± 3 %
 max. 10 mA

IMPORTANT! Brief interruptions in the power supply e.g.caused, by it being switched by an electromechanical relay, can cause the electronics to malfunction.

Further technical data for stepper motor Cat no 9638

Control: bipolar, by means of SAA 1042 A (Motorola)
 stepper motor driver or equivalent with drop resistance of 44 Ω per phase at a driver (full-step) operating voltage of 24 V ±5 %, or by means of a constant current driver set to 0.4A.

Resistance per phase: 9 Ω
 Inductance per phase: 12 mH
 Steps for opening angle of 90°: 2028

See publication D112901 for further technical data for the motor drive with CAN interface 9657.

Wiring diagrams
01

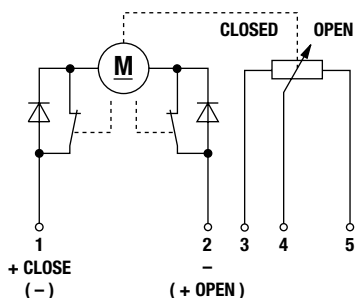

DC motor

Wiring:
 +to 1 Direction of operation: CLOSE
 -to 2 Direction of operation: OPEN
 +to 2 Direction of operation: OPEN
 -to 1
 Cutoff at limits provided by microswitches
 Resistance between 3 and 4:
 minimum value – valve closed
 maximum value – valve opened

02

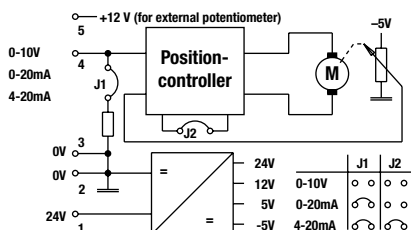

DC motor

Wiring :
 1 and 2 Power supply
 3 and 4 Input control voltage
 5 Output/auxiliary

03

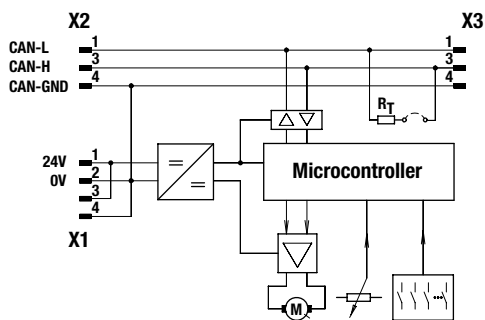

DC motor

Wiring:
 X1 Power supply
 1 und 2
 X2, X3
 1 CAN bus signal (dominant low)
 3 CAN bus signal (dominant high)
 4 CAN earth

04

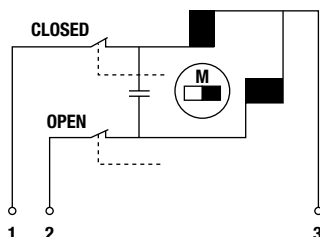

Synchronous motor

Wiring:
 AC to 1 and 3 Direction of operation: CLOSE
 2 unused
 AC to 2 and 3 Direction of operation: OPEN
 1 unused
 Cutoff at limits provided by microswitches

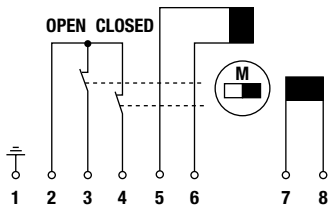

Stepper motor

Wiring:

- 1 Motor frame (possibly for screening)
- 2 Reference potential for contacts
- 3 Limit feedback signal (OPEN) contact opened at limit
- 4 Limit feedback signal (CLOSED) contact opened at limit
- 5 and 6 Connections for phase 1
- 7 and 8 Connections for phase 2

Notes on choice of motor

Buschjost offers various valve designs and a choice of DC, synchronous and stepper motors catering for the wide range of applications of the motorised valve and the customer's needs.

The mechanical contacts of DC motors make them unsuitable for control functions involving a large number of small adjustments. The AC synchronous motors last longer thanks to their absence of contacts. A stepper motor has to be used where frequent and/or fine adjustment is required.

The following table shows the characteristics of the components used.

		Motor life (running time)	Recommended pulse duration	Recommended interval without current during reversal in direction of rotation
DC motor	9615	500 h	> 100 msec	600 msec
DC motor	9624	500 h	> 100 msec	250 msec
DC motor	9650, 9657, 9651	500 h	-	-
Synchronous motor	9636	1000 h	> 100 msec	40 msec
Stepping motor	9638	1000 h	Stepping frequency 200 Hz	-

- To provide a temperature regulation system, the motorised valve can be combined with the 9368 drive, the 82690 microprocessor-controlled PID three-point stepper regulator (Publication 7501533) and the 1244362 digital temperature sensor.
- Further drive models and electronic controllers available on request.
- Flow regulation kit available on request

Further models

- XXXXX60.96XX FPM seat seal, control discs for k_{vs} 1,1
- XXXXX61.96XX EPDM seat seal, control discs for k_{vs} 1,1
- XXXXX62.96XX Control discs for k_{vs} 3,4 p_{max} 6 bar, only for G 1/2 and cartridge models
- XXXXX64.96XX EPDM seat seal, control discs for k_{vs} 3,4 p_{max} 6 bar, only for G 1/2 and cartridge models
- XXXXX75.96XX Oxygen model, assembled without oil and grease, sealing material FPM

On request

- Stainless steel model
- Separate drive, max fluid temperature 130°C
- Other models/combinations
- Control discs for k_{vs} values

Sectional dimension diagrams

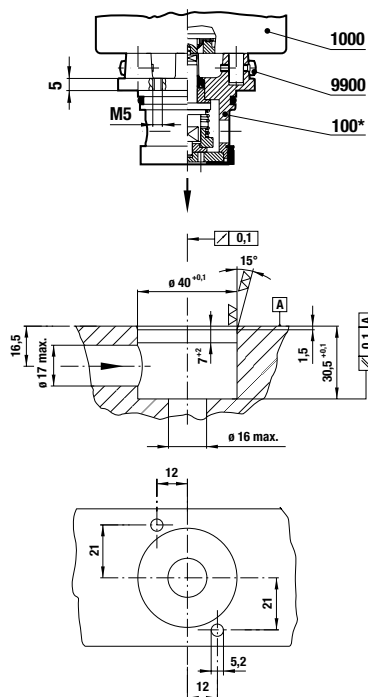

- *100 Valve cartridge
- 1000 Motor drive
- 9900 Cheese-head screw

Sectional diagrams

to G 1/2

up to G 3/4

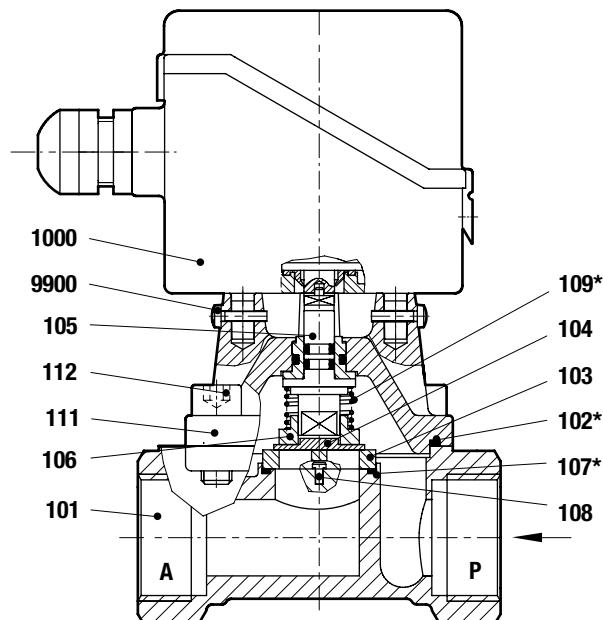
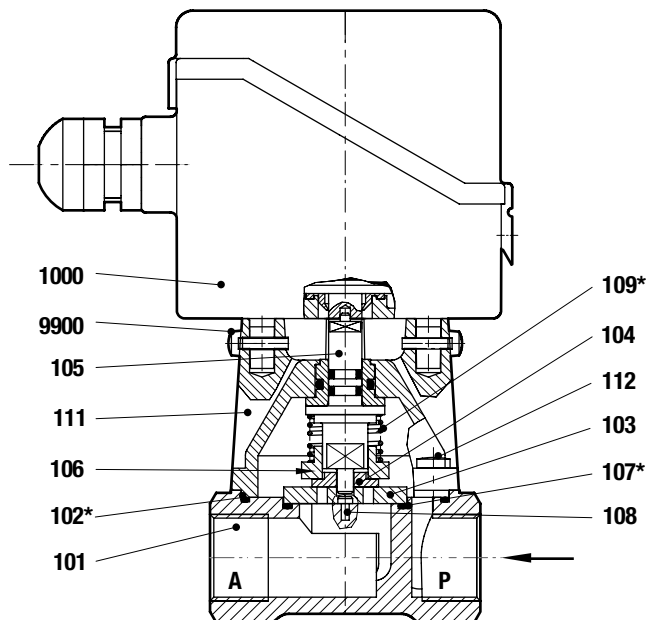

- 101 Valve body
- *102 O-ring
- 103 Disc
- 104 Disc
- *105 Valve spindle
- 106 Holder
- *107 O-ring

- 108 Pin
- *109 Compression spring
- 111 Bodycover 112 G 1/2 flat head screw
- 112 Allen screw for G 3/4 and G1
- 1000 Motor drive
- 9900 Fillister-head screw

* These individual parts form a complete wearing unit.
When ordering spare parts please state Cat no and series no.

Dimension diagrams

to DN 25

up to DN 32

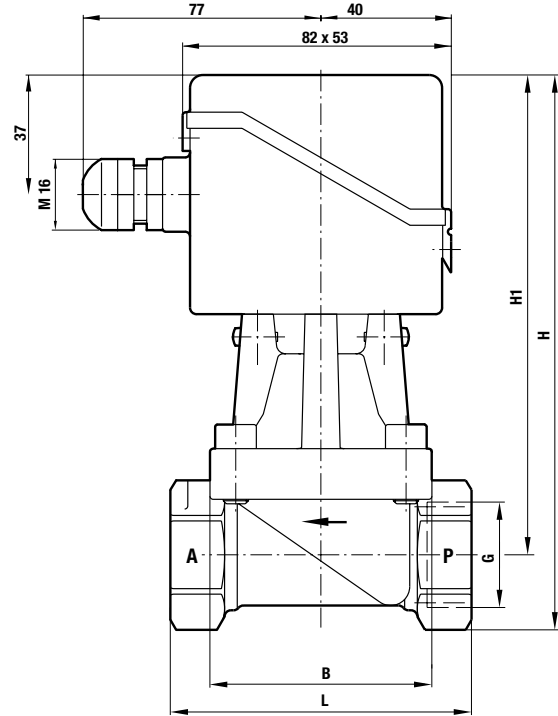
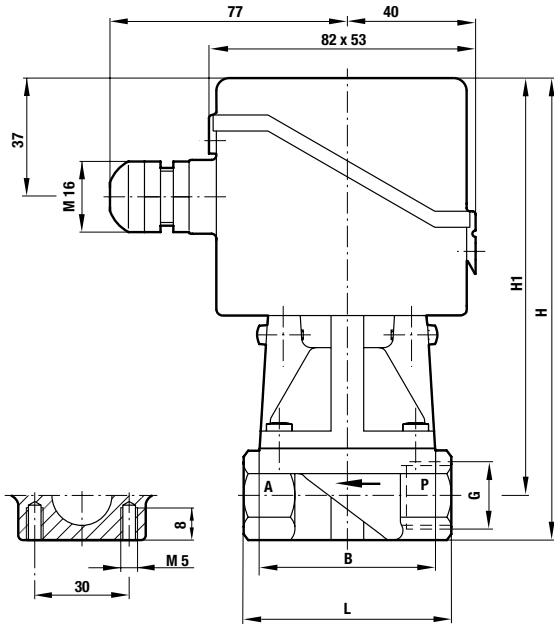

Part Number	Nominal Diameter (mm)	Connection size	L (mm)	B (mm)	H (mm)	H1 (mm)
8288200.96XX	15	G 1/2	65	55	147	134
8288300.96XX	20	G 3/4	95	70	164	140
8288400.96XX	20	G 1	95	70	164	140

Note to Pressure Equipment Directive (PED):

The valves of this series are according to Art. 3 § 3 of the Pressure Equipment Directive (PED) 97/23/EG. This means interpretation and production are in accordance to engineers practice wellknown in the member countries. The CE-sign at the valve does not refer to the PED. Thus the declaration of conformity is not longer applicable for this directive.

Note to Electromagnetic Compatibility Guideline (EEC):

The valves shall be provided with an electrical circuit which ensures the limits of the harmonised standards EN 61000-6-3 and EN 61000-6-1 are observed, and hence the requirements of the Electromagnetic Compatibility Guideline (2004/108/EEC) satisfied.